

**RESOLUTION OF THE
BOARD OF DIRECTORS OF THE
TRAILS AT CROWFOOT METROPOLITAN DISTRICT NO. 3**

**ESTABLISHING POLICIES AND PROCEDURES FOR
THE MAINTENANCE OF FIVE GLOBE LIGHTS**

WHEREAS, Trails at Crowfoot Metropolitan District No. 3, in the Town of Parker, State of Colorado (the “**District**”), is a quasi-municipal corporation and political subdivision of the State of Colorado; and

WHEREAS, the District has the power to provide certain public infrastructure, improvements and services, as described in Title 32, Article 1, C.R.S. (the “**Special District Act**”), within and without its boundaries (collectively, the “**Public Improvements**”), as authorized and in accordance with the Amended and Restated Service Plan for Hess Ranch Metropolitan District No. 3 to be known as Trails at Crowfoot Metropolitan District No. 3 approved by the Town of Parker on June 17, 2019 (the “**Service Plan**”); and

WHEREAS, the District, Trails at Crowfoot Metropolitan District No. 1 (“**District No. 1**”), and Trails at Crowfoot Metropolitan District No. 2 (“**District No. 2**”) are parties to that certain Amended and Restated District Operating Agreement effective June 17, 2019 (the “**IGA**”); and

WHEREAS, pursuant to the terms of the IGA, among other things, the District shall own, operate and maintain Public Improvements not otherwise required to be dedicated to the Town of Parker or other governmental entities or an owners association; and

WHEREAS, the Board of Directors (the “**Board**”) of the District desires to adopt a policy whereby it will maintain certain Public Improvements, more specifically the five globe lights, located within its boundaries; and

WHEREAS, in an effort to clarify the requirements for maintenance of the five globe lights, the District desires to follow, to the extent practicable, the maintenance standards as set forth in this Resolution, and as may be amended from time to time in the District’s sole discretion.

NOW, THEREFORE, be it resolved by the Board as follows:

1. Maintenance of Five Globe Lights. After construction of the five globe lights and acceptance of the underlying real property by the Town of Parker, the District shall be responsible for the maintenance of the five globe lights at the locations identified in **Exhibit A** attached hereto and incorporated herein by this reference (the “**Light Locations**”). Maintenance of the five globe lights includes but is not limited to replacement of the five globe lights when damaged and repainting the five globe lights at regular intervals in the District’s sole discretion. The details and specifications for the replacement of the five globe lights are shown in **Exhibit B** attached hereto and incorporated herein by this reference (the “**Details and Specifications**”).

2. Subject to Annual Appropriations. This Resolution shall not constitute a multi-fiscal year obligation of the District, and any policies of the District as provided herein shall be subject to annual appropriation by the Board.

3. No Waiver. No waiver of any of the provisions of this Resolution shall be deemed to constitute a waiver of any other of the provisions of this Resolution, nor shall such waiver constitute a continuing waiver unless otherwise expressly provided herein.

[Signature page follows.]

ADOPTED this 26th day of October, 2023.

DISTRICT:

TRAILS AT CROWFOOT

METROPOLITAN DISTRICT NO. 3, a quasi-municipal corporation and political subdivision of the State of Colorado

By: *Sarah Hunsche*

Officer of District

Attest:

By: COREY ELLIOTT

COREY ELLIOTT (Nov 6, 2023 14:31 MST)

Secretary

Exhibit A
Light Locations

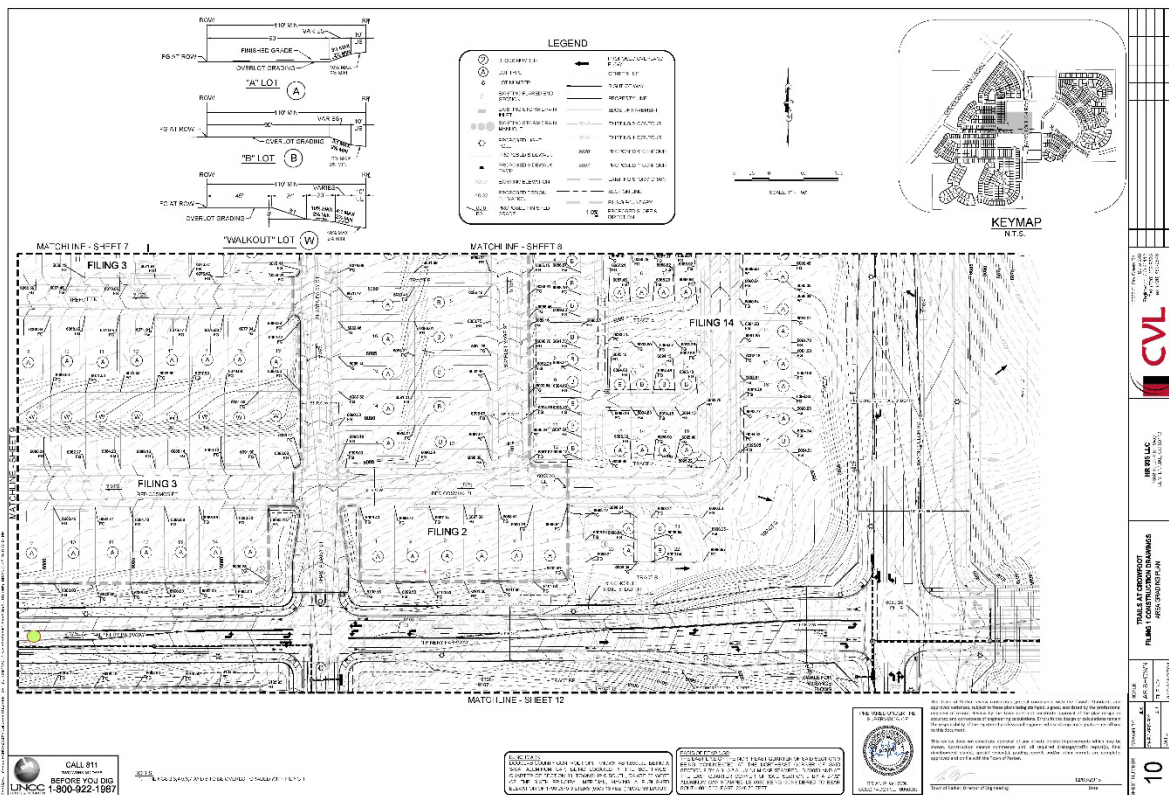
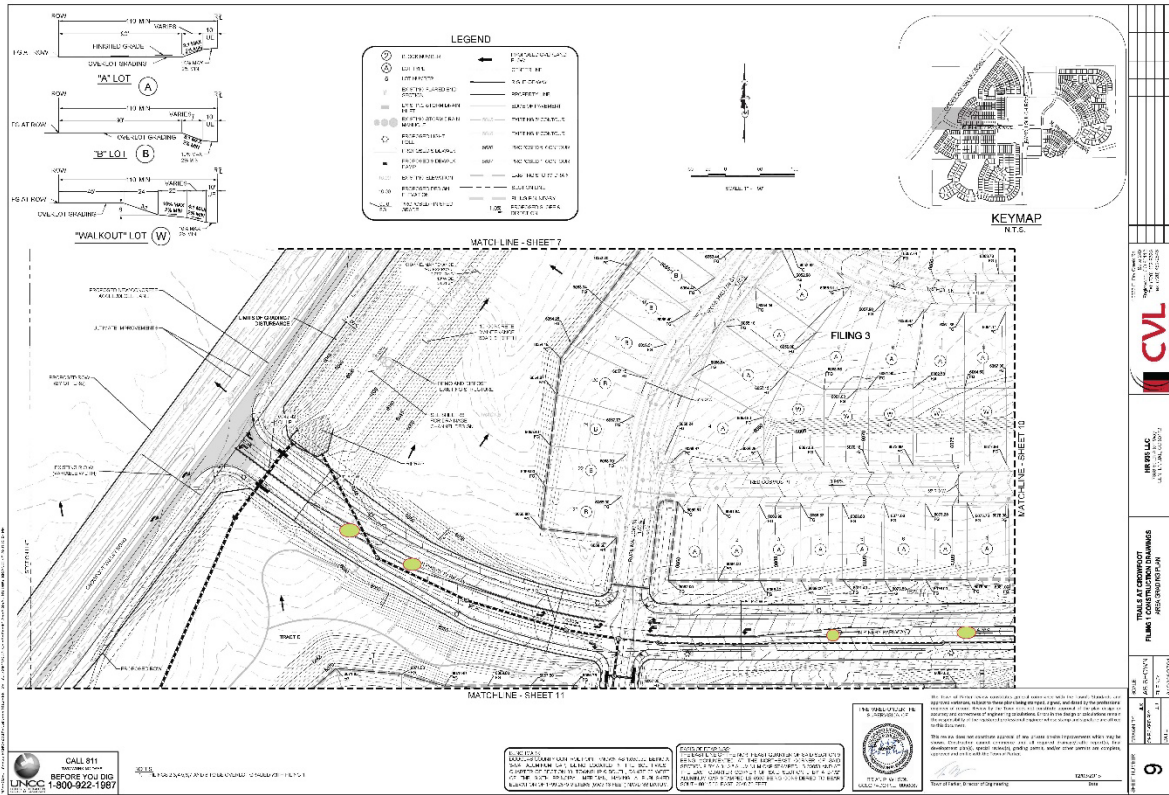
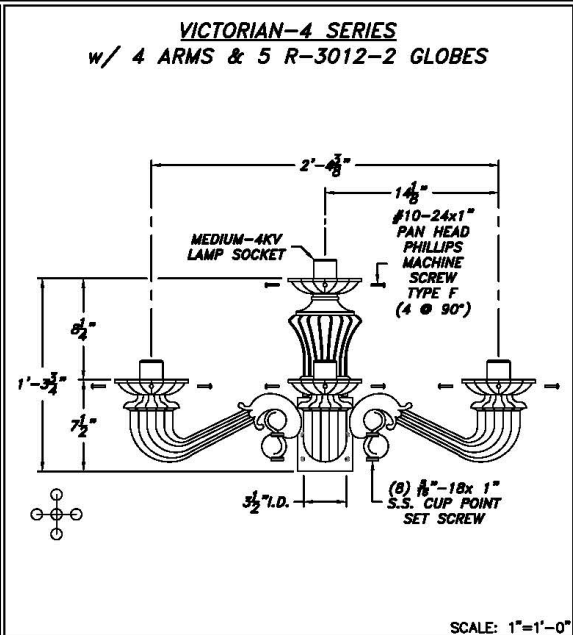
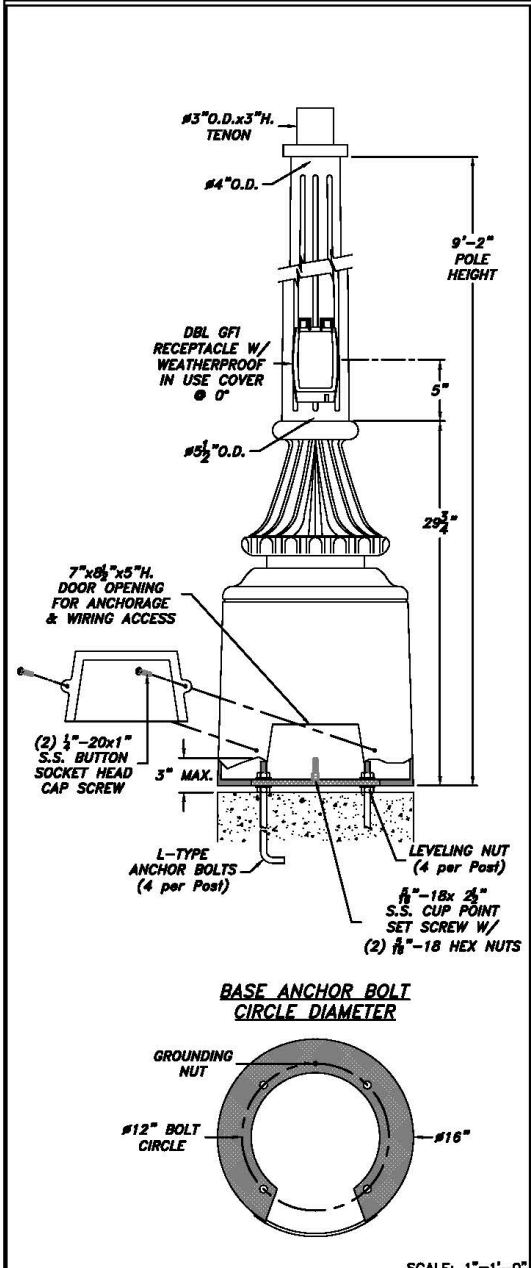
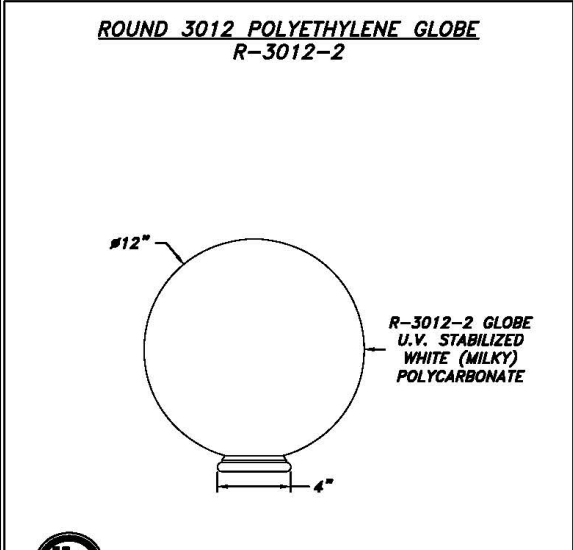

Exhibit B
Details and Specifications



VP4-5-8-3012- INC - N/A - 120 - TR
 Ballast Watts Volts Color



SCALE: 1 1/2"=1'-0"

VICTORIAN-103 SERIES-16" BASE-FLUTED ALUMINUM SHAFT-9'-2" POLE HEIGHT-TAPER RESISTANT WEATHERPROOF GFI RECEPTACLE W/ IN USE COVER
 VP-103-9.2-TRWPGFI-IUC

Catalog Name: VP-103-TF-9.2-VP4-5C-3012-TRWPGFI-IUC Date: 07.08.15
 Revision History: N/A Revision #: 0
 Niland Approval: Luis M. Gomez Customer Approval: _____ Page: 2 of 2

NILAND COMPANY • PH: (915) 779-1400 • FAX: (915) 779-3818 • E-MAIL: INFO@NILANDCO.COM
 380 N. Clark St. P.O. Box, Ft. Worth, TX 76105 • PH: 800-646-9013 • FAX: 800-779-3065 • WEB PAGE: HTTP://WWW.NILANDCO.COM